

## SPECIFICATIONS FOR LCD MODULE



### DS-C2004A3-BTSSWE-NAA

20 CHARACTERS X 4 LINES

OUTLINE DIMENSION: 98.0 X 60.0 MM

VIEWING AREA: 76.0 X 25.2 MM

CHARACTER SIZE: 2.96 X 4.75 MM

CHARACTER PITCH: 3.55 X 5.35 MM

TEMPERATURE: WIDE

#### REVISION RECORD

REV.	DATE	PAGE	CONTENT
1.0	2012-04-11		NEW RELEASE

## **CONTENTS**

- LCD MODULE NUMBERING SYSTEM
- PHYSICAL DATA
- EXTERNAL DIMENSIONS
- CIRCUIT BLOCK DIAGRAM
- ABSOLUTE MAXIMUM RATINGS
- ELECTRICAL CHARACTERISTICS
- BACKLIGHT CHARACTERISTICS
- ELECTRO-OPTICAL CHARACTERISTICS
- INSTRUCTION TABLE
- INITIALIZING BY INSTRUCTION
- INTERNAL CHARACTER GENERATOR FONT
- EXAMPLE FOR SOFTWARE APPLICATION
- INSPECTION STANDARDS
- PRECAUTIONS IN USING LCM

# DISTAR TECHNOLOGY LIMITED

## ■ LCD MODULE NUMBERING SYSTEM

**DS-C2004A-** \_ \_ \_ \_ \_ - \_ \_ \_ \_ \_

①    ②    ③    ④    ⑤    ⑥    ⑦    ⑧    ⑨

**DS**     DISTAR TECHNOLOGY

**C**       CHARACTER TYPE

**2004**   SERIALS NUMBER FOR CM    20 CHARACTERS Vs. 4 LINES

**A**       VERSION OF PCB

NO	Remark	Code Value	Description
①	LCD Type	Y	STN yellow/green type LCD
		B	STN blue type LCD
		G	STN gray type LCD
		F	FSTN positive type LCD
		N	FSTN negative type LCD
		P	TN positive type LCD
		E	TN negative type LCD
②	Polarizer Type	R	Reflective type
		F	Transflective type
		T	Transmissive type
③	Viewing Angel	S	Six o'clock
		T	Twelve o'clock
④	Backlight Type	N	Without backlight
		E	EL backlight
		C	CCFL backlight
		D	Bottom LED backlight
		S	Side LED backlight
⑤	Backlight Color	N	Without backlight
		Y	Yellow/green
		W	White
		G	Green
		B	Blue
		A	Amber
		O	Orange
⑥	LCM Temperature Type	N	Normal
		E	Extended
		S	Super extended
⑦	DC-DC Converter Circuit	N	Without
		Y	With
⑧	Power Supply For Logic	A	5.0V
		B	3.3V
⑨	Power Supply For Backlight	A	5.0V
		B	4.2V
		C	3.3V

# DISTAR TECHNOLOGY LIMITED

## ■ PHYSICAL DATA

Item	Content	Unit
LCD type	STN blue, Negative, Transmissive	---
LCD duty	1/16	---
LCD bias	1/5	---
Viewing direction	6	o'clock
Module size	98.0 x 60.0 x 14.0 (max)	mm
Viewing area	76.0 x 26.0	mm
Number of characters	20 x 4	dots
Character size	2.96x 4.75	mm
Character pitch	3.55 x 5.35	mm
Character format	5 X 7 dots with cursor	---
Backlight type	Side LED backlight	---
Color of backlight	White	---
Driver IC	SPLC780D or Eqv.	---

## ■ EXTERNAL DIMENSIONS

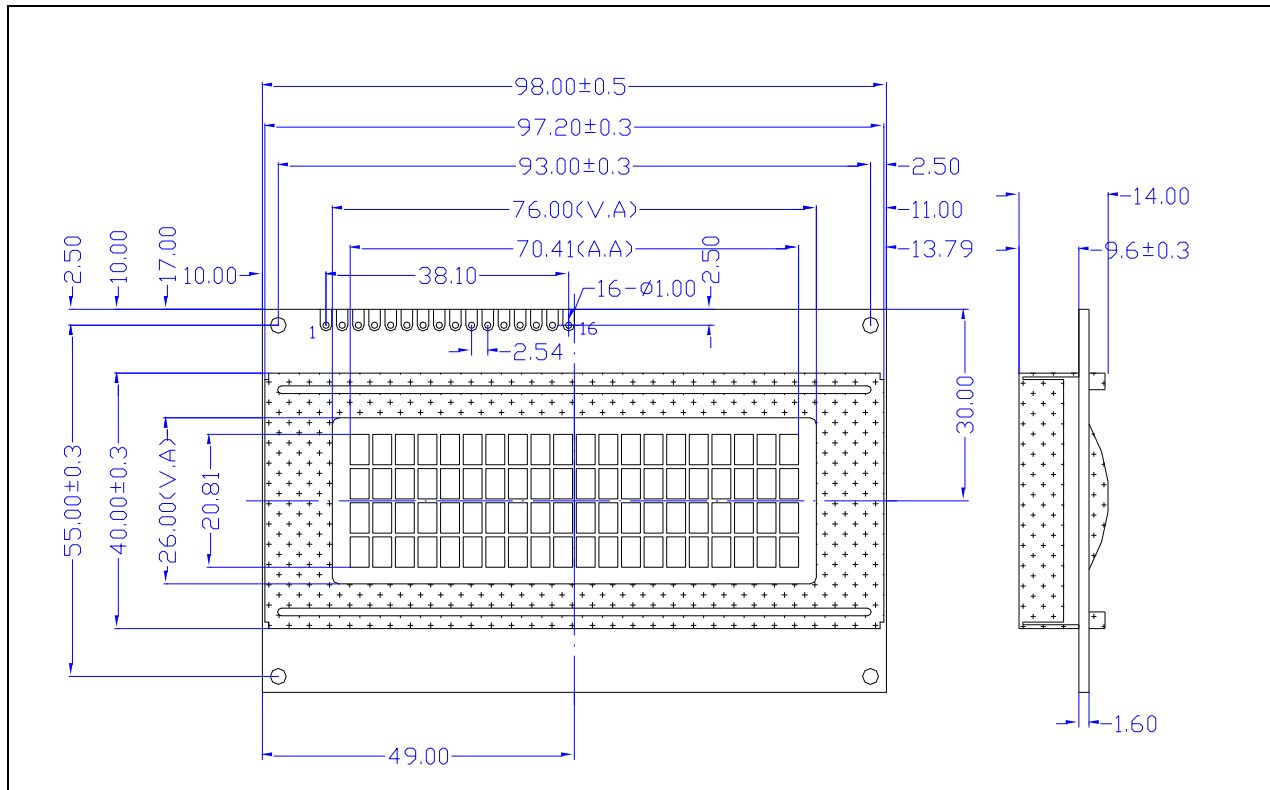

NOTE: THE FRAME IS CONNECTED TO VSS  
 THE TOLERANCE IS  $\pm 0.2\text{MM}$  UNLESS OTHERWISE NOTED.

# DISTAR TECHNOLOGY LIMITED

## ■ CIRCUIT BLOCK DIAGRAM

### ◇ Electrical Block Diagram

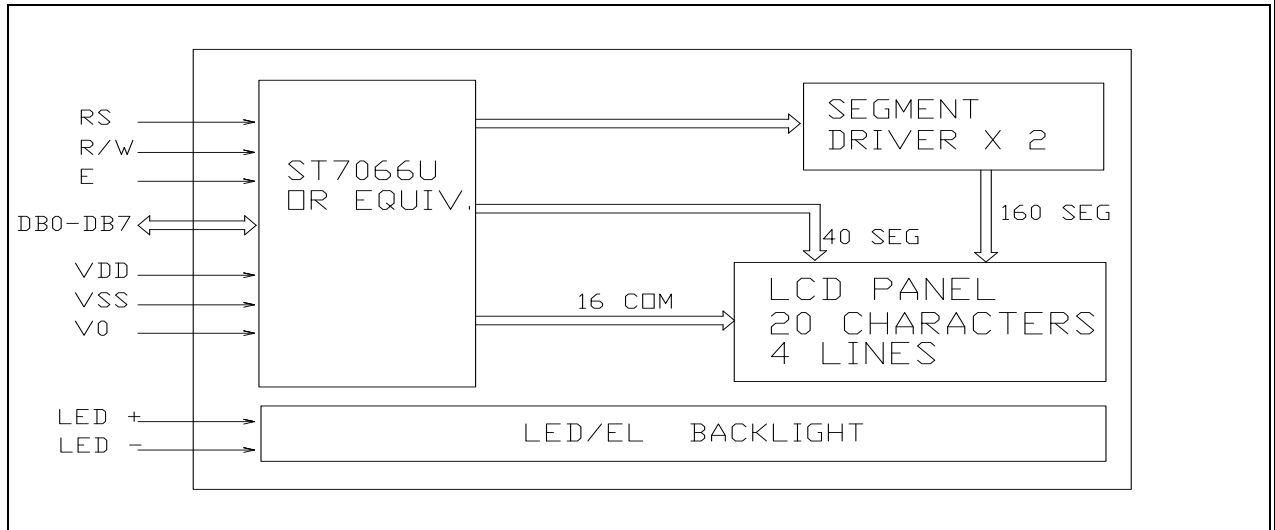

### ◇ Pins Definition

PIN	SYMBOL	LEVEL	FUNCTION
1	V <sub>SS</sub>	0	Power Supply(GND)
2	V <sub>DD</sub>	5.0V	Power Supply For Logic(+5.0v)
3	V <sub>0</sub>	—	Input Voltage For LCD
4	RS	H/L	H: Data Signal , L: Instruction Signal
5	R/W	H/L	H: Read mode , L: Write mode
6	E	H,H→L	Enable Signal
7	DB <sub>0</sub>	H / L	Data Bus Lines
8	DB <sub>1</sub>	H / L	
9	DB <sub>2</sub>	H / L	
10	DB <sub>3</sub>	H / L	
11	DB <sub>4</sub>	H / L	
12	DB <sub>5</sub>	H / L	
13	DB <sub>6</sub>	H / L	
14	DB <sub>7</sub>	H / L	
15	A	+5.0V	Power Supply For LED Backlight (+) (5.0v)
16	K	0 V	Power Supply For LED Backlight (-) (0v)

# DISTAR TECHNOLOGY LIMITED

◇ Power supply

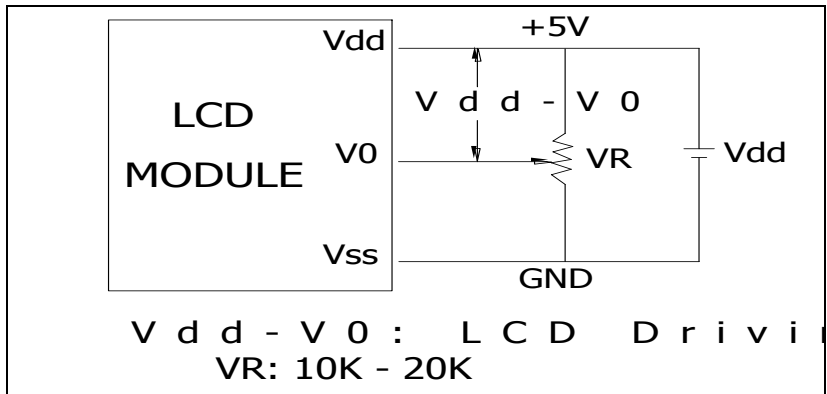

◇ Display character address code

POSITION	1	2	3	4	5	6	---	--	--	---	---	16	17	18	19	20	
ADDRESS SS	LINE1	00	01	02	03	04	05	--	--	---	---	0F	10	11	12	13	
	LINE2	40	41	42	43	44	45	---	---	---	---	4F	50	51	52	53	
	LINE3	14	15	16	17	18	19	--	--	---	---	---	23	24	25	26	27
	LINE4	54	55	56	57	58	59	---	---	---	---	---	63	64	65	66	67

\*NOTE: ALL OF THE NUMBERS ARE IN HEX FORMAT

■ ABSOLUTE MAXIMUM RATINGS(Ta=25°C)

◇ Electrical Absolute Maximum Ratings

ITEM	SYMBOL	CONDITON	MIN	MAX	UNIT
Supply Voltage For Logic	Vdd – Vss	-	-0.3	7.0	V
Supply Voltage For LCD	Vdd – V0	-	0	13.0	V
Input Voltage	Vi	-	-0.3	Vdd +0.3	V

◇ Environmental Absolute Maximum Ratings

ITEM	SYMBOL	CONDITON	MIN	MAX	UNIT
Operating temperature	Topr	-Normal temp. version-	-20	70	deg C
Operating temperature	Ttsg		-30	80	deg C
Humidity Endurance	RH	no condensation Ta<=40 deg	-	95	%
Vibration	-	100-300Hz, X/Y/Z directions, 1 hour	-	4.9m/ss 0.5g	-

# DISTAR TECHNOLOGY LIMITED

Shock	-	10 mS X/Y/Z direction 1 time each		29.4m/ss 3.0g	-
-------	---	---	--	------------------	---

## ■ ELECTRICAL CHARACTERISTICS

### ◇ DC Characteristics

Electrical Characteristics at Ta=25 deg C, Vdd = 5V + / - 5%

ITEM	SYMBOL	CONDITION	MIN	TYP	MAX	UNIT
Supply Voltage For Logic	Vdd-Vss	-	4.5	5.0	5.5	V
Supply Voltage For LCD	Vdd-V0	Vdd = 5V	-	4.8	-	V
Input Signal Voltage(for RS, DB0-7,R/W,E)	V-ih	“H”level	2.2	-	Vdd	V
	V-il	“L”level	0	-	0.6	V
Supply Current For Logic	Icc	-	-	1	1.2	mA
Supply Current For LCD	Io	-	0.15	0.22	0.27	mA

### ◇ AC Characteristics

Timing Specification at Ta=25 deg C ,Vdd=5V+/-10% , Vss=0V

#### ◆ Write mode

ITEM	SYMBOL	TEST PIN	MIN	TYP	MAX	UNIT
E cycle time	tc	E	500	-	-	ns
E rise time	tR	E	-	-	25	ns
E fall time	tF	E	-	-	25	ns
E-pulse width (H, L)	tw	E	220	-	-	ns
R/W and RS set-up time	tsul	R/W,RS	40	-	-	ns
R/W and RS hold time	tH1	R/W,RS	10	-	-	ns
Data set-up time	tsu2	DB0—DB7	60	-	-	ns
Data hold time	tH2	DB0—DB7	10	-	-	ns

# DISTAR TECHNOLOGY LIMITED

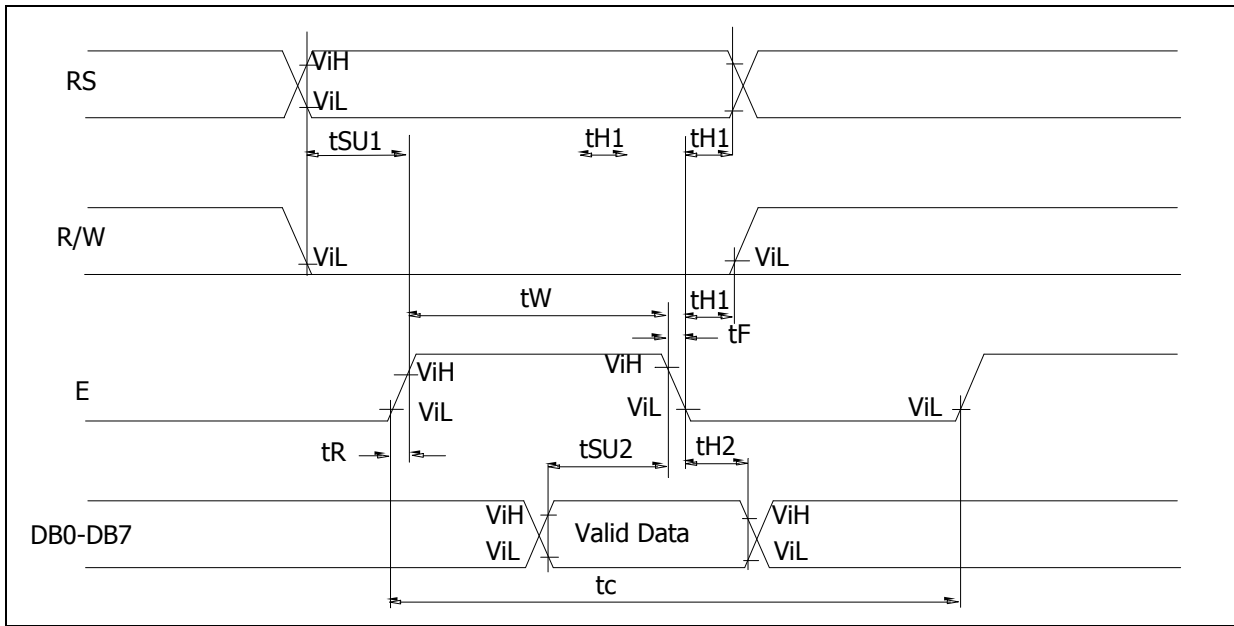

◆ Read mode

ITEM	SYMBOL	TEST PIN	MIN	TYP	MAX	UNIT
E cycle time	tc	E	500	-	-	ns
E rise time	tR	E	-	-	25	ns
E fall time	tF	E	-	-	25	ns
E-pulse width (H, L)	tw	E	220	-	-	ns
R/W and RS set-up time	tsu	R/W,RS	40	-	-	ns
R/W and RS hold time	tH	R/W,RS	10	-	-	ns
Data output delay	tD	DB0—DB7	-	-	120	ns
Data hold time	tDH	DB0—DB7	20	-	-	ns

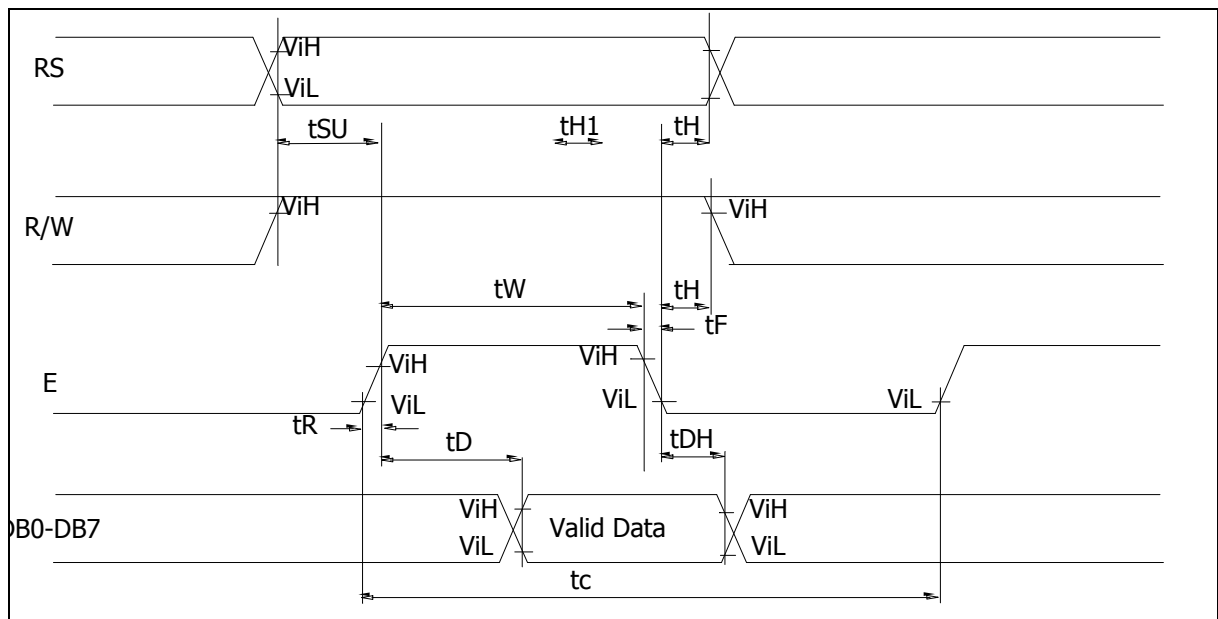



# DISTAR TECHNOLOGY LIMITED

## ■ BACKLIGHT CHARACTERISTICS

Unless specified, the Ambient temperature  $T_a=25\text{ }^\circ\text{C}$

ITEM	SYMBOL	MIN	TYP	MAX	UNIT	CONDITION
Supply Voltage	Vf	4.0	5.0	5.5	V	
Forward Current	Ifm		60		mA	Vf=5.0V
Reverse Voltage	Vr		-	4.0	V	
Power Dissipation	Pd				mW	Vf=5.0V
Operation Temperature Range	Topr	-20		+70	$^\circ\text{C}$	
Storage Temperature Range	Tstg	-30		+80	$^\circ\text{C}$	
Peak Wavelength	$\lambda_p$				nm	Vf=5.0V
Luminance	Lv	90	220		Cd/m <sup>2</sup>	Vf=5.0V
LED Life Time	L		50000		Hrs	Ta=25 $^\circ\text{C}$ Vf=5.0V



LED CIRCUIT DIAGAM (LED 1X3=3 dies)

## ■ ELECTRO-OPTICAL CHARACTERISTICS

ITEM	SYMBOL	CONDITION	MIN.	TYP.	MAX.	UNIT	REF.
Contrast	CR	25 $^\circ\text{C}$	--	12	--		Note1
Rise Time	tr	25 $^\circ\text{C}$	--	160	240	ms	Note2
Fall Time	tf	25 $^\circ\text{C}$	--	100	150	ms	note 2
Viewing Angle	$\theta_1-\theta_2$	25 $^\circ\text{C}$	--	--	60	DEG	Note 3
	$\emptyset_1, \emptyset_2$		-40	--	40		
Frame Frequency	Ff	25 $^\circ\text{C}$	--	70	--	Hz	note 2

Note(1): Contrast ratio is defined under the following condition:

- CR=  $\frac{\text{brightness of selected condition}}{\text{brightness of non-selected condition}}$
- (a). Temperature-----25C
  - (b). Frame Frequency-----64Hz
  - (c). Viewing angle----- $\theta=0, \emptyset=0$
  - (d). Operating Voltage---5.0V

Note(2): definition of response time:

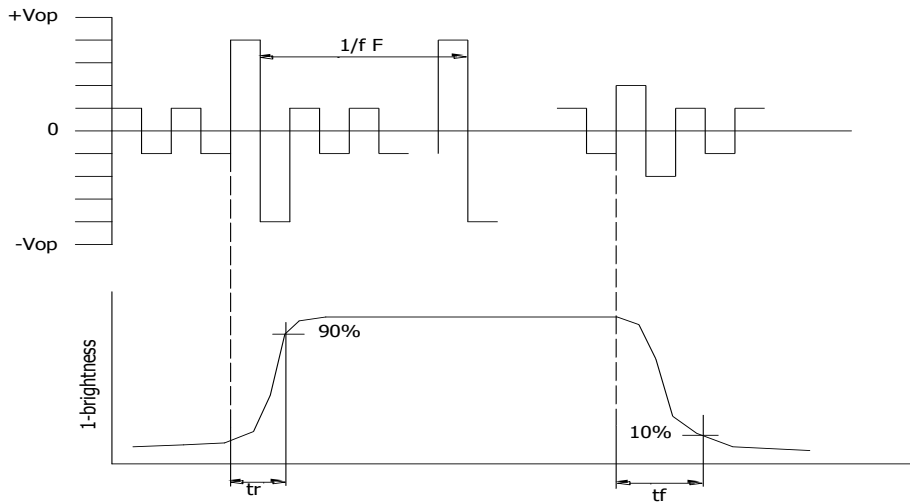

Condition:

- (a). Temperature-----25C
- (b). Frame Frequency-----64Hz
- (c). Viewing angle----- $\theta=0, \phi=0$
- (d). Operating Voltage---5.0V

Note(3): definition of view angle:

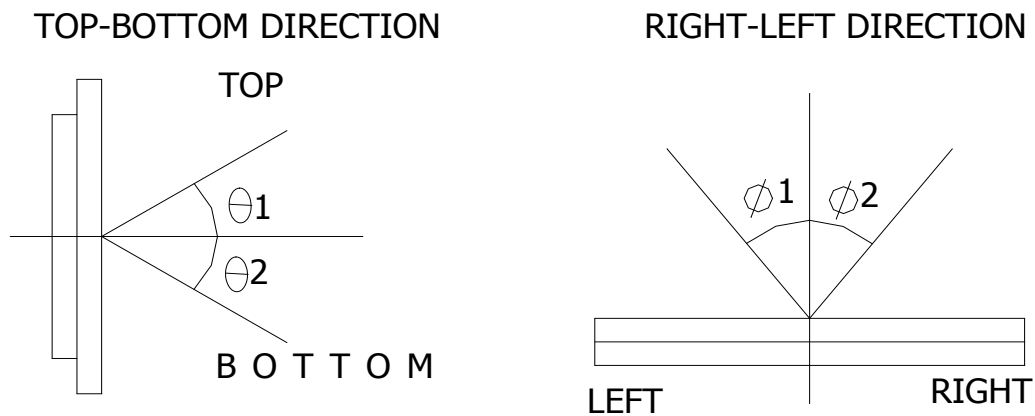

■ INSTRUCTION TABLE

# DISTAR TECHNOLOGY LIMITED

Function	R	R	D	D	D	D	D	D	D	D	Description	Execu Time* (Max)	
	S	W	B	B	B	B	B	B	B	B			
			7	6	5	4	3	2	1	0			
<b>Clear Display</b>	0	0	0	0	0	0	0	0	0	1	Clears entire display and returns the cursor to home position (address 0)	1.64mS	
<b>Return Home</b>	0	0	0	0	0	0	0	0	0	1	X	Return the cursor to the home position. DD RAM contents remain unchanged. Set DD RAM address to zero.	1.64mS
<b>Entry mode set</b>	0	0	0	0	0	0	0	0	1	1	S	Set cursor moving direction and enable the shift of the display. These operations are performed during data write/read of DD RAM/CG RAM. 1/D=1: increment; 1/D=0: decrement; S=1: whole display shift when data is written.	40μS
<b>Display ON/OFF control</b>	0	0	0	0	0	0	1	D	C	B		Set display (D), cursor (C) and blinking of cursor (B) ON/OFF. D=1: display ON; D=0: display OFF. C=1: Cursor ON; C=0: cursor OFF. B=1: Blink ON; B=0, Blink OFF.	40μS
<b>Cursor or Display shift</b>	0	0	0	0	0	1	S	R	X	X		Move the cursor and shift the display without changing DDRAM contents. S/C=1: Display Shift; S/C=0: Cursor move. R/L=1: shift to right; R/L=0: shift to left.	40μS
<b>Function Set</b>	0	0	0	0	1	D	N	F	X	X		Set interface data length (DL), number of display lines (N) and character font (F). DL=1: 8 bits; DL=0: 4 bits. N=1: 2 lines; N=0: 1 lines. F=1: 5X11 dots; F=0: 5X7 dots.	40μS
<b>Set CG RAM add</b>	0	0	0	1							ACG	Set CG RAM address. CG RAM data is sent and received after this setting.	40μS
<b>Set DD RAM Add</b>	0	0	1								ADD	Set DD RAM address. DD RAM data is sent and received after this setting.	40μS
<b>Read BF &amp; Addr</b>	0	1	B								AC	Read BUSY FLAG (BF) and the contents of the address counter. BF=1: internal operation; BF=0: can accept instruction.	0μS
<b>Write Data to RAM</b>	1	0									WRITE DATA	Write data into DD RAM or CG RAM.	40 μS**
<b>Read Data from RAM</b>	1	0									READ DATA	Read data from DD RAM or CG RAM.	40 μS**

# DISTAR TECHNOLOGY LIMITED

## ■ INITIALIZING BY INSTRUCTION

◇ 8-bit Interface Mode(Condition: fosc=270kHz)

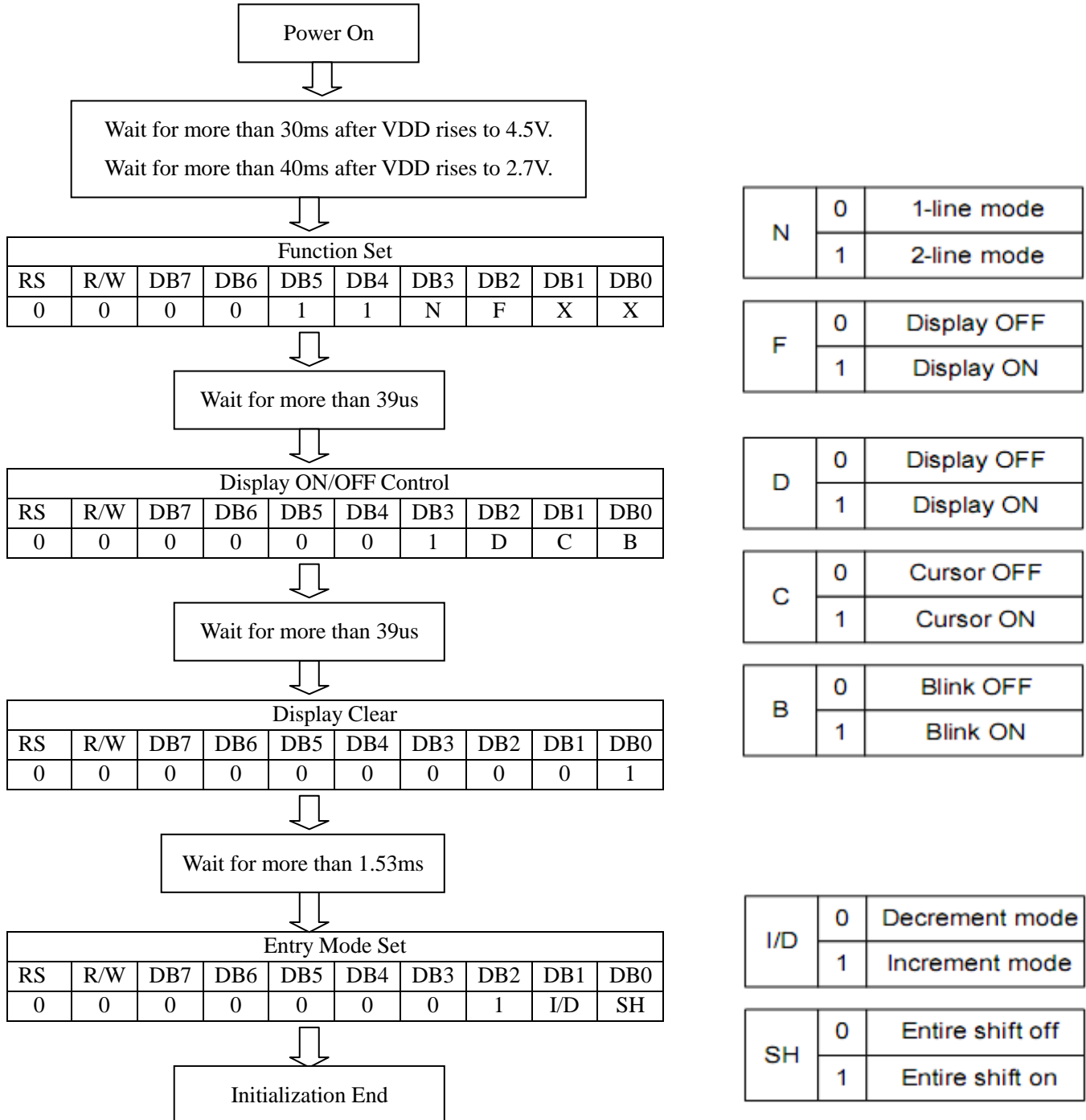

# DISTAR TECHNOLOGY LIMITED

◇ 4-bit Interface Mode(Condition: fosc=270kHz)

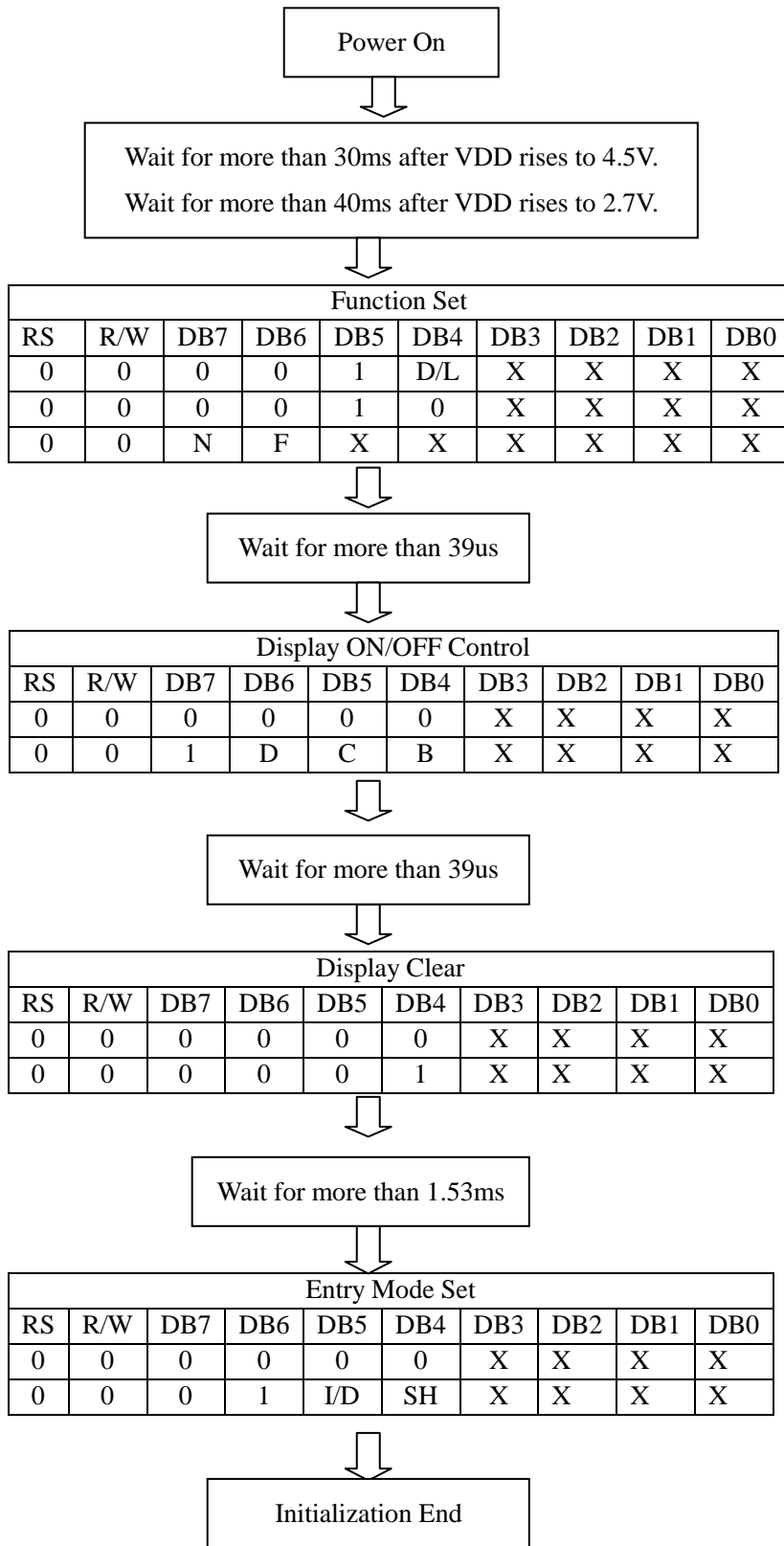

D/L	0	4-bit mode
	1	8-bit mode

N	0	1-line mode
	1	2-line mode

F	0	Display off
	1	Display on

D	0	Display off
	1	Display on

C	0	Cursor off
	1	Cursor on

B	0	Blink off
	1	Blink on

I/D	0	Decrement mode
	1	Increment mode

SH	0	Entire shift off
	1	Entire shift on

# DISTAR TECHNOLOGY LIMITED

## INTERNAL CHARACTER GENERATOR FONT

Upper 4 bit Lower 4 bit	LLLL	LLHH	LLHL	LLHH	HLHL	HLHH	HLHL	HLHH	LLLL	LLHH	HLHL	HLHH	LLLL	LLHH	HLHL	HLHH
LLLL				0	1	2	3	4	5	6	7	8	9	A	B	C
LLHH			!	1	A	Q	a	y			.	ア	チ	△	△	△
LLHL			"	2	B	R	b	r			「	イ	ウ	×	β	β
LLHH			#	3	C	S	c	s			」	ウ	子	モ	モ	モ
LHLL			\$	4	D	T	d	t			、	エ	ト	ト	ト	ト
LHLH			%	5	E	U	e	u			・	オ	オ	工	工	工
LHHL			&	6	F	V	f	v			ヲ	カ	ニ	ヨ	ヨ	ヨ
LHHH			'	7	G	W	g	w			ヲ	キ	ヌ	ラ	ラ	ラ
HLLL			(	8	H	X	h	x			イ	ウ	キ	リ	リ	リ
HLLH			)	9	I	V	i	v			ウ	ケ	ル	ル	ル	ル
HLHL			*	:	J	Z	j	z			エ	コ	レ	レ	レ	レ
HLHH			+	:	K	L	k	l			オ	サ	ロ	ロ	ロ	ロ
HHLL			,	<	L	Y	l	y			カ	シ	フ	フ	フ	フ
HHLH			-	=	M	J	m	j			ユ	ヌ	シ	シ	シ	シ
HHHL			.	>	N	^	n	^			ヨ	セ	ホ	ホ	ホ	ホ
HHHH			/	?	O	_	o	_			ウ	リ	マ	マ	マ	マ

## ■ EXAMPLE FOR SOFTWARE APPLICATION

**8-BIT OPERATION 20 characters X 4 lines**

.....

**4-bit operation (4-bits 1 line)**

.....

## ■ INSPECTION STANDARDS

- ◇ The LCD shall be inspected under 40W white fluorescent light.  
The distance between the eyes and the samples shall be more than 30cm.  
All directions for inspecting the sample should be within 45 degree against perpendicular line.

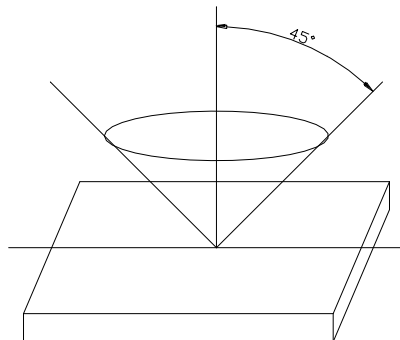

## ◇ Definition of Applicable Zone

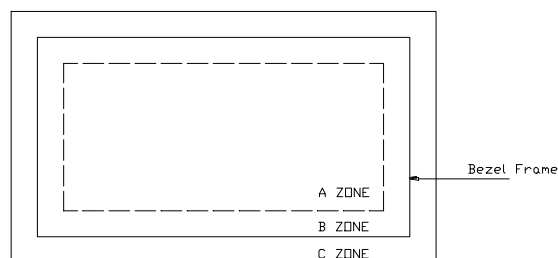

- A Zone: Active Display Area
- B Zone: Area from Bezel Frame to A Zone
- C Zone: Rest Area of Bezel
- A Zone + B Zone=Effective Viewing Area

# DISTAR TECHNOLOGY LIMITED

◇ Standards

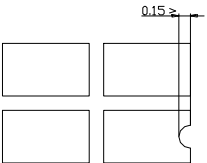
NO	PARAMETER	CRITERIA																																																											
1	Black and White Spots, Foreign Substances	<p style="text-align: center;"><b>Round Shape</b></p> <table border="1" style="width: 100%; border-collapse: collapse;"> <thead> <tr> <th style="width: 60%;">Zone</th> <th colspan="3">Acceptable Number</th> </tr> <tr> <th>DIMENSION(MM)</th> <th style="width: 16.6%;">A</th> <th style="width: 16.6%;">B</th> <th style="width: 16.6%;">C</th> </tr> </thead> <tbody> <tr> <td style="text-align: center;"><math>D \leq 0.1</math></td> <td style="text-align: center;">*</td> <td style="text-align: center;">*</td> <td style="text-align: center;">*</td> </tr> <tr> <td style="text-align: center;"><math>0.1 &lt; D \leq 0.2</math></td> <td style="text-align: center;">5</td> <td style="text-align: center;">5</td> <td style="text-align: center;">*</td> </tr> <tr> <td style="text-align: center;"><math>0.2 &lt; D \leq 0.3</math></td> <td style="text-align: center;">0</td> <td style="text-align: center;">1</td> <td style="text-align: center;">*</td> </tr> <tr> <td style="text-align: center;"><math>0.3 &lt; D</math></td> <td style="text-align: center;">0</td> <td style="text-align: center;">0</td> <td style="text-align: center;">*</td> </tr> </tbody> </table> <p style="text-align: center;"><math>D = (\text{long} + \text{short}) / 2</math>    * Disregard</p> <p style="text-align: center;"><b>Line Shape</b></p> <table border="1" style="width: 100%; border-collapse: collapse;"> <thead> <tr> <th colspan="2">Zone</th> <th colspan="3">Acceptable Number</th> </tr> <tr> <th style="width: 20%;">X(mm)</th> <th style="width: 20%;">Y(mm)</th> <th style="width: 16.6%;">A</th> <th style="width: 16.6%;">B</th> <th style="width: 16.6%;">C</th> </tr> </thead> <tbody> <tr> <td style="text-align: center;">-</td> <td style="text-align: center;"><math>0.02 \geq W</math></td> <td style="text-align: center;">*</td> <td style="text-align: center;">*</td> <td style="text-align: center;">*</td> </tr> <tr> <td style="text-align: center;"><math>2.0 \geq L</math></td> <td style="text-align: center;"><math>0.03 \geq W</math></td> <td style="text-align: center;">3</td> <td style="text-align: center;">3</td> <td style="text-align: center;">*</td> </tr> <tr> <td style="text-align: center;"><math>1.0 \geq L</math></td> <td style="text-align: center;"><math>0.04 \geq W</math></td> <td style="text-align: center;">1</td> <td style="text-align: center;">2</td> <td style="text-align: center;">*</td> </tr> <tr> <td style="text-align: center;"><math>1.0 \geq L</math></td> <td style="text-align: center;"><math>0.05 \geq W</math></td> <td style="text-align: center;">0</td> <td style="text-align: center;">2</td> <td style="text-align: center;">*</td> </tr> <tr> <td style="text-align: center;">-</td> <td style="text-align: center;"><math>0.05 &lt; W</math></td> <td colspan="3" style="text-align: center;"><b>Not acceptable</b></td> </tr> </tbody> </table> <p style="text-align: center;">X: Length    Y: Width    * Disregard  <b>Total defects shall not exceed 5.</b></p>	Zone	Acceptable Number			DIMENSION(MM)	A	B	C	$D \leq 0.1$	*	*	*	$0.1 < D \leq 0.2$	5	5	*	$0.2 < D \leq 0.3$	0	1	*	$0.3 < D$	0	0	*	Zone		Acceptable Number			X(mm)	Y(mm)	A	B	C	-	$0.02 \geq W$	*	*	*	$2.0 \geq L$	$0.03 \geq W$	3	3	*	$1.0 \geq L$	$0.04 \geq W$	1	2	*	$1.0 \geq L$	$0.05 \geq W$	0	2	*	-	$0.05 < W$	<b>Not acceptable</b>		
Zone	Acceptable Number																																																												
DIMENSION(MM)	A	B	C																																																										
$D \leq 0.1$	*	*	*																																																										
$0.1 < D \leq 0.2$	5	5	*																																																										
$0.2 < D \leq 0.3$	0	1	*																																																										
$0.3 < D$	0	0	*																																																										
Zone		Acceptable Number																																																											
X(mm)	Y(mm)	A	B	C																																																									
-	$0.02 \geq W$	*	*	*																																																									
$2.0 \geq L$	$0.03 \geq W$	3	3	*																																																									
$1.0 \geq L$	$0.04 \geq W$	1	2	*																																																									
$1.0 \geq L$	$0.05 \geq W$	0	2	*																																																									
-	$0.05 < W$	<b>Not acceptable</b>																																																											
2	Air Bubbles (Between glass and polarizer)	<table border="1" style="width: 100%; border-collapse: collapse;"> <thead> <tr> <th style="width: 60%;">Dimension(mm) \ Zone</th> <th colspan="3">Acceptable Number</th> </tr> <tr> <th></th> <th style="width: 16.6%;">A</th> <th style="width: 16.6%;">B</th> <th style="width: 16.6%;">C</th> </tr> </thead> <tbody> <tr> <td style="text-align: center;"><math>D \leq 0.1</math></td> <td style="text-align: center;">*</td> <td style="text-align: center;">*</td> <td style="text-align: center;">*</td> </tr> <tr> <td style="text-align: center;"><math>0.1 &lt; D \leq 0.2</math></td> <td style="text-align: center;">5</td> <td style="text-align: center;">5</td> <td style="text-align: center;">*</td> </tr> <tr> <td style="text-align: center;"><math>0.2 &lt; D \leq 0.3</math></td> <td style="text-align: center;">0</td> <td style="text-align: center;">1</td> <td style="text-align: center;">*</td> </tr> <tr> <td style="text-align: center;"><math>0.3 &lt; D</math></td> <td style="text-align: center;">0</td> <td style="text-align: center;">0</td> <td style="text-align: center;">*</td> </tr> </tbody> </table> <p style="text-align: center;">*: Disregard  <b>Total defects shall not exceed 3.</b></p>	Dimension(mm) \ Zone	Acceptable Number				A	B	C	$D \leq 0.1$	*	*	*	$0.1 < D \leq 0.2$	5	5	*	$0.2 < D \leq 0.3$	0	1	*	$0.3 < D$	0	0	*																																			
Dimension(mm) \ Zone	Acceptable Number																																																												
	A	B	C																																																										
$D \leq 0.1$	*	*	*																																																										
$0.1 < D \leq 0.2$	5	5	*																																																										
$0.2 < D \leq 0.3$	0	1	*																																																										
$0.3 < D$	0	0	*																																																										
3	The Shape of Dot	<p>(1) Dot Shape(with dent)</p> <div style="text-align: center;">  </div> <p>As per the sketch of left hand.</p> <p>(2) Dot Shape(with Projection)</p>																																																											

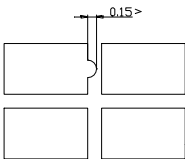
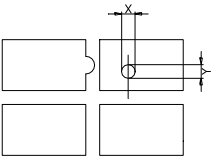

# DISTAR TECHNOLOGY LIMITED

		 <p style="text-align: center;">Should not connect to next dot.</p> <p style="text-align: center;">(3) Pin Hole</p>  <p style="text-align: center;"><math>(X+Y)/2 &lt; 0.2\text{mm}</math> (less than 0.1mm is not counted)</p> <p style="text-align: center;">Total defects shall not exceed 5.</p>
4	Polarizer Scratches	<b>Not to be conspicuous defects.</b>
5	Polarizer Dirts	If the stains are removed easily from LCD surface, the module is not defective.
6	Color Variation	<b>Not to be conspicuous defects.</b>

## ■ PRECAUTIONS IN USING LCM

### ◇ LIQUID CRYSTAL DISPLAY (LCD)

LCD is made up of glass, organic sealant, organic fluid, and polymer based polarizers. The following precautions should be taken when handling,

- (1). Keep the temperature within range of use and storage. Excessive temperature and humidity could cause polarization degradation, polarizer peel off or bubble.
- (2). Do not contact the exposed polarizers with anything harder than an HB pencil lead. To clean dust off the display surface. Wipe gently with cotton. Chamois or other soft material soaked in petroleum benzin.
- (3). Wipe off saliva or water drops immediately. Contact with water over a long period of time may cause polarizer deformation or color fading, while an active LCD with water condensation on its surface will cause corrosion of ITO electrodes.
- (4). Glass can be easily chipped or cracked from rough handling, especially at corners and edges.
- (5). Do not drive LCD with DC voltage.

### ◇ Liquid Crystal Display Modules

#### ◆ Mechanical Considerations

LCM are assembled and adjusted with a high degree of precision. Avoid excessive shocks and do not make any alterations or modifications. The following should be noted.

- (1). Do not tamper in any way with the tabs on the metal frame.
- (2). Do not modify the PCB by drilling extra holes, changing its outline, moving its components or modifying its pattern.
- (3). Do not touch the elastomer connector, especially insert an backlight panel (for example, EL).
- (4). When mounting a LCM make sure that the PCB is not under any tress such as bending or twisting. Elastomer contacts are very delicate and missing pixels could result from slight

# DISTAR TECHNOLOGY LIMITED

dislocation of any of the elements.

- (5). Avoid pressing on the metal bezel, otherwise the elastomer connector could be deformed and lose contact, resulting in missing pixels.

## ◆ Static Electricity

LCM contains CMOS LSI's and the same precaution for such devices should apply, namely

- (1). The operator should be grounded whenever he/she comes into contact with the module. Never touch any of the conductive parts such as the LSI pads, the copper leads on the PCB and the interface terminals with any parts of the human body.
- (2). The modules should be kept in antistatic bags or other containers resistant to static for storage.
- (3). Only properly grounded soldering irons should be used.
- (4). If an electric screwdriver is used, it should be well grounded and shielded from commutator sparks.
- (5). The normal static prevention measures should be observed for work clothes and working benches; for the latter conductive (rubber) mat is recommended.
- (6). Since dry air is inductive to statics, a relative humidity of 50-60% is recommended.

## ◆ Soldering

- (1). Solder only to the I/O terminals.
- (2). Use only soldering irons with proper grounding and no leakage.
- (3). Soldering temperature:  $280\text{ }^{\circ}\text{C} \pm 10^{\circ}\text{C}$
- (4). Soldering time: 3 to 4 sec.
- (5). Use eutectic solder with resin flux fill.
- (6). If flux is used, the LCD surface should be covered to avoid flux spatters. Flux residue should be removed afterwards.

## ◆ Operation

- (1). The viewing angle can be adjusted by varying the LCD driving voltage  $V_0$ .
- (2). Driving voltage should be kept within specified range; excess voltage shortens display life.
- (3). Response time increases with decrease in temperature.
- (4). Display may turn black or dark blue at temperatures above its operational range; this is (however not pressing on the viewing area) may cause the segments to appear "fractured".
- (5). Mechanical disturbance during operation (such as pressing on the viewing area) may cause the segments to appear "fractured".

## ◆ Storage

If any fluid leaks out of a damaged glass cell, wash off any human part that comes into contact with soap and water. Never swallow the fluid. The toxicity is extremely low but caution should be exercised at all the time.

## ◆ Limited Warranty

Unless otherwise agreed between DISTAR and customer, DISTAR will replace or repair any of its LCD and LCM, which is found to be defective electrically and visually when inspected in accordance with DISTAR acceptance standards, for a period on one year from data of shipment. Confirmation of such date shall be based on freight documents. The warranty liability of DISTAR is limited to repair and/or replacement on the terms set forth above. DISTAR will not responsible for any subsequent or consequential events.

END