



makeblock

Global Leader in STEAM Education Solutions

CONTENTS

makeblock

01 | Product Introduction

02 | Parts List

03 | 3-in-1 Model

Product Introduction

mBot add-on Pack- Talkative Pet

The mBot add-on Pack-Talkative Pet is a 3-in-1 add-on pack for mBot. By using the audio player, micro servo and other mechanical parts in the pack, three cases can be created based on mBot, including "Robot Dog," "Rover" and "Robot Penguin," that can sing and talk, making three times the fun.

- Add-on pack for mBot
- 3-in-1 model: "Robot Dog," "Rover" and "Robot Penguin"
- Comes with audio player (SD card included), each robot can sing and talk, making three times the fun.

Note: The add-on pack cannot be used without a Makeblock mBot Li-polymer battery or a 18650 Li-polymer battery, which needs to be purchased separately.

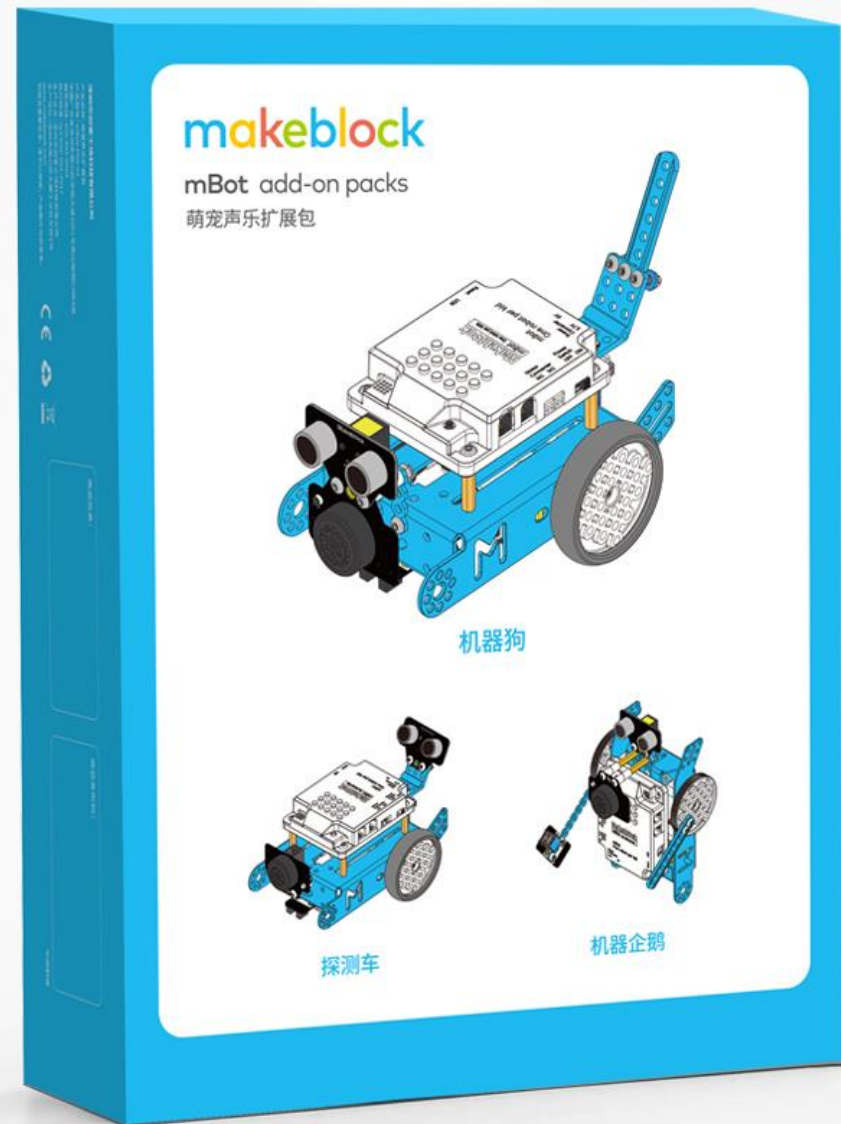

P1060007

Parts List

Part Name	Quantity
Audio Player (SD card included)	1
9g Micro Servo	1
RJ25 Adapter	1
18650 Battery Holder	1
RJ25 Cable-20cm	2
Beam 076	1
Bracket 120° 3x3	1
Cuttable Linkage 3 Hole	2
Cuttable Linkage 4 Hole	3
Cuttable Linkage	1
Plastic Spacer 4*7*3	15
Plastic Spacer 4*7*10	6
M4 Nut	14
M4 Lock Nut	6
M4*30mm Screw	4
M4*22mm Screw	4
M4*16mm Screw	4
M4*8mm Screw	10
Wrench	1

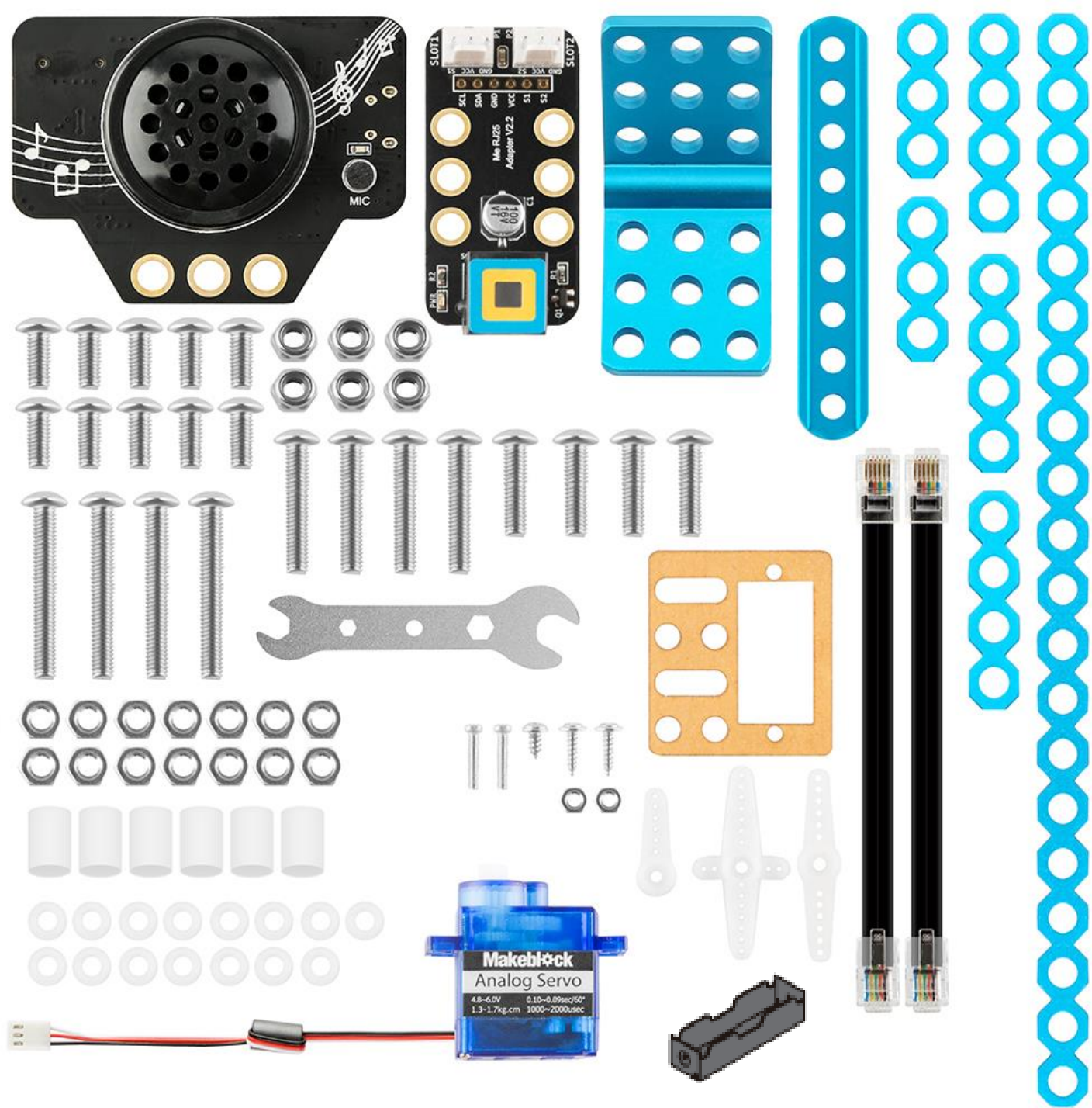

3-in-1 Model: Robot Dog

Introduction

With a "mouth" that can sing and talk and a naughty "tail," mBot becomes a smart pet - a robot dog that can run, bark, sing, jump, wag its tail to amuse you, and interact with you. It is so cute!



3-in-1 Model: Robot Dog

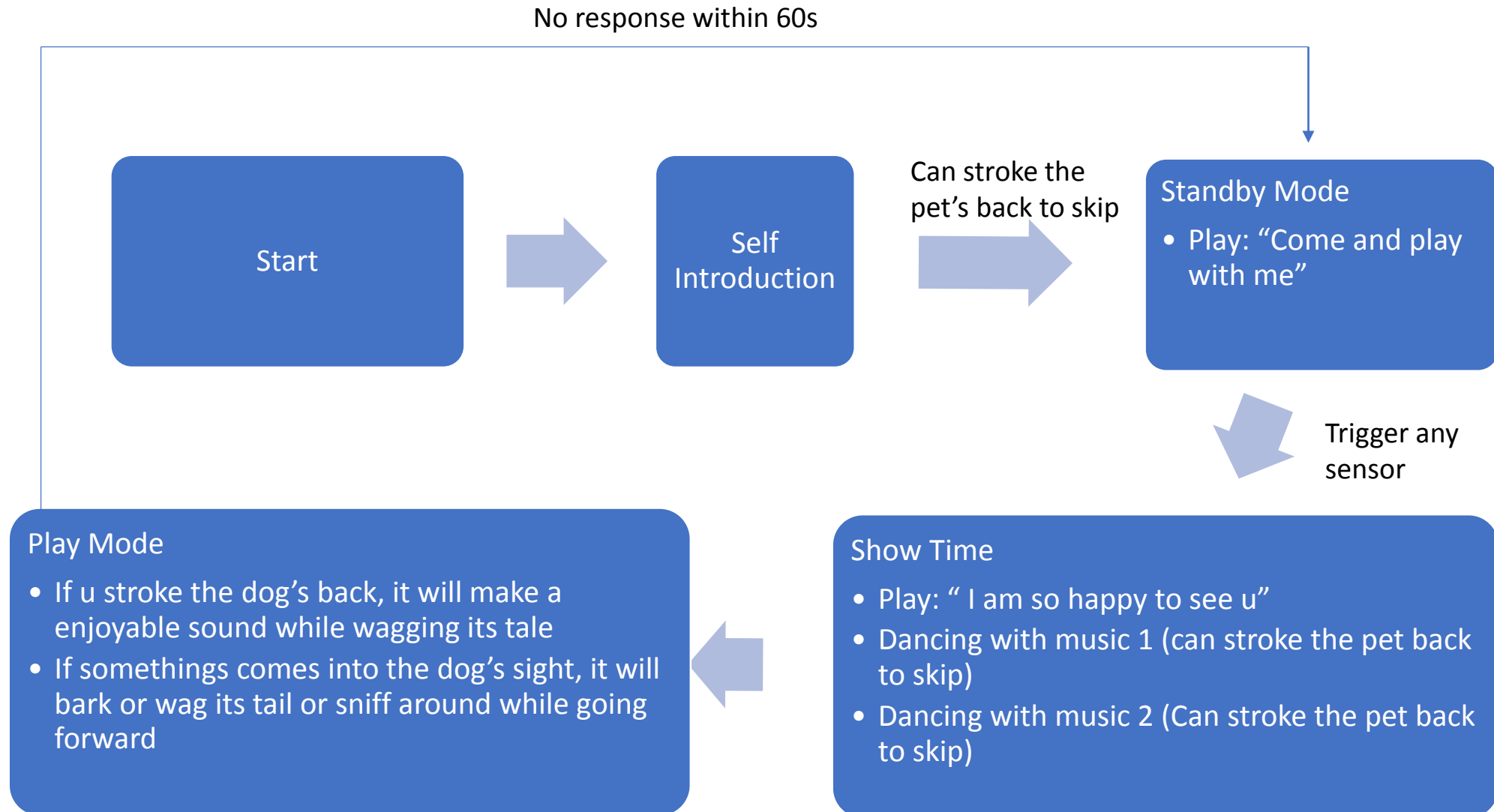

3-in-1 Model: Rover

Introduction

Ultrasonic sensor is used for repeated detection in the 10 o'clock, 12 o'clock and 2 o'clock positions. If an object is detected ahead, the rover will report it in a cute voice, and emit a red light while heading to the object. When the distance to the object is less than 28cm, the rover will alert you about the obstacle and turn to avoid it.

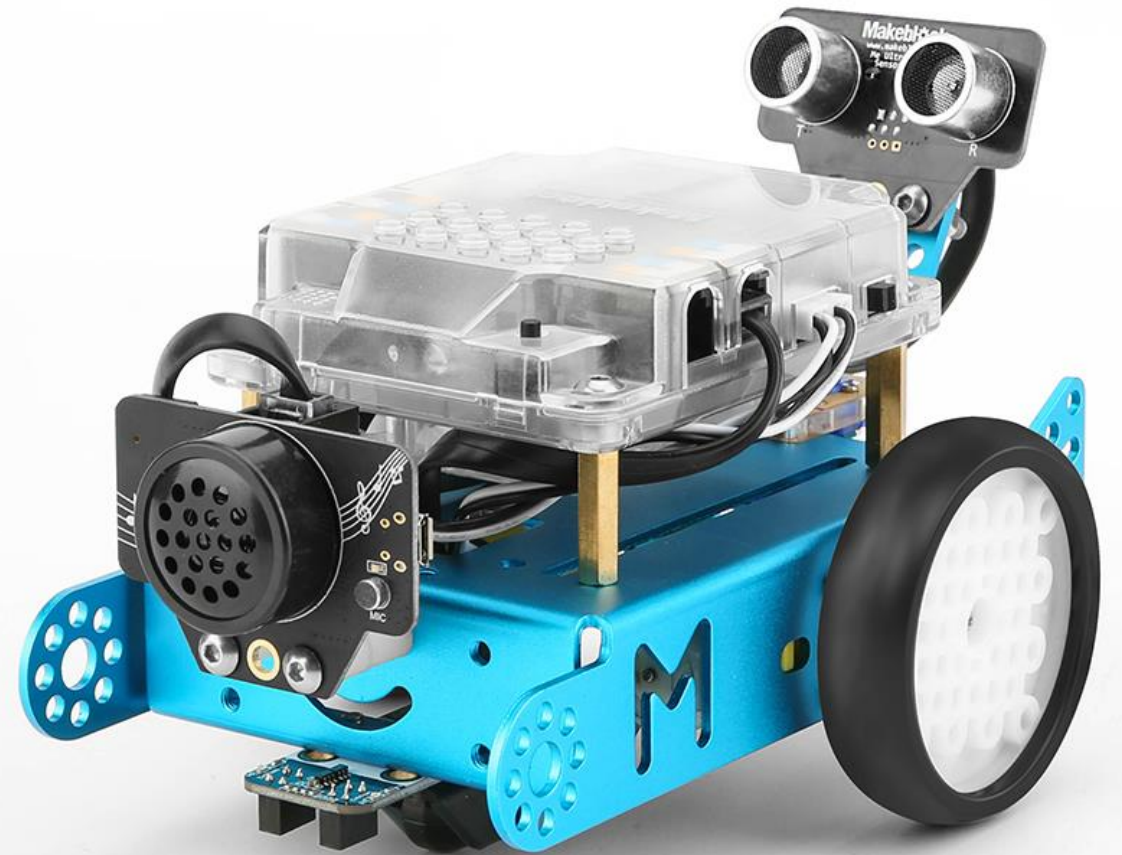

3-in-1 Model: Rover

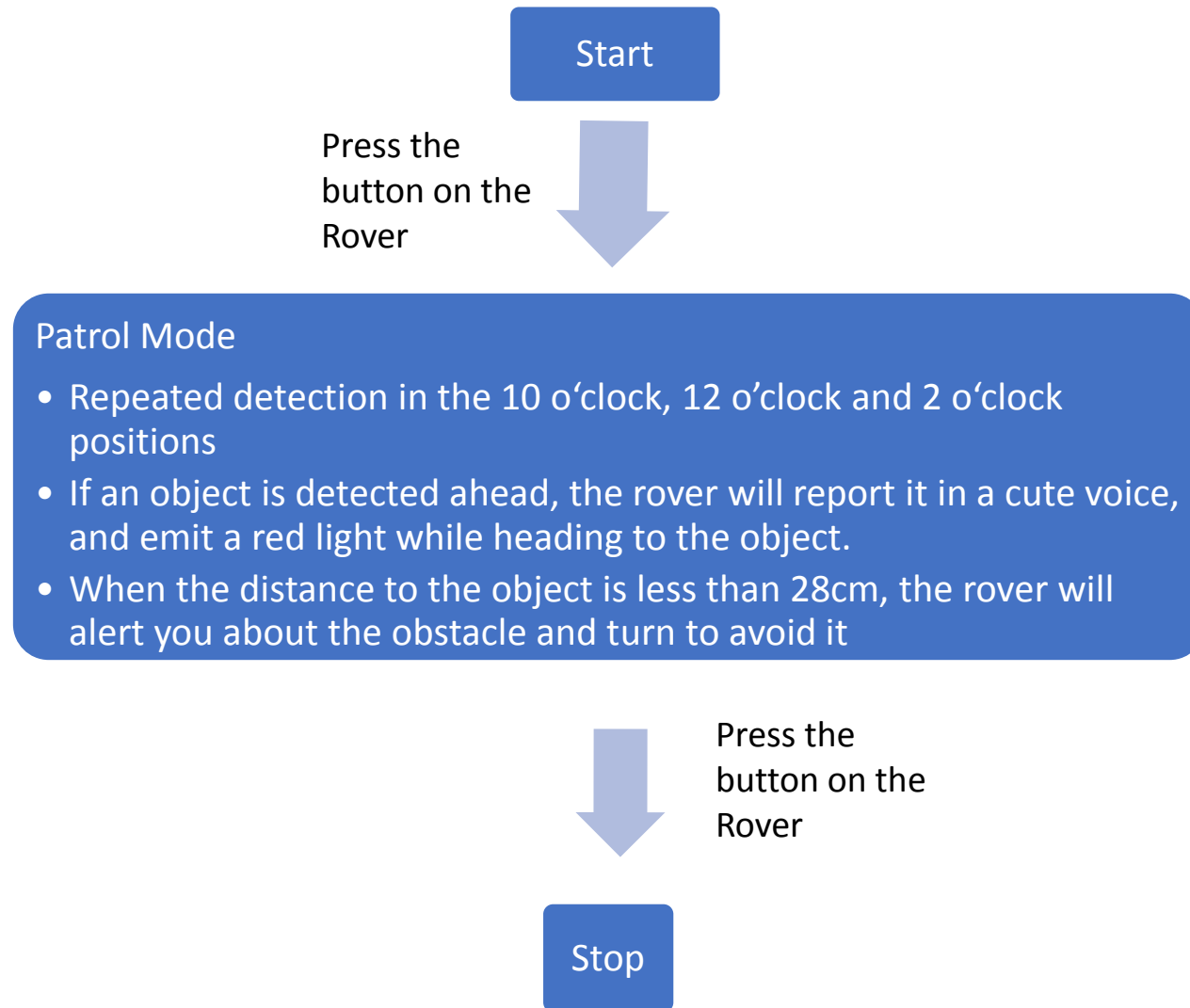

3-in-1 Model: Robot Penguin

Introduction

By changing the case, mBot easily turns into an adorable robot penguin that can tell stories, jokes, sing and dance, and even shake hands with you.

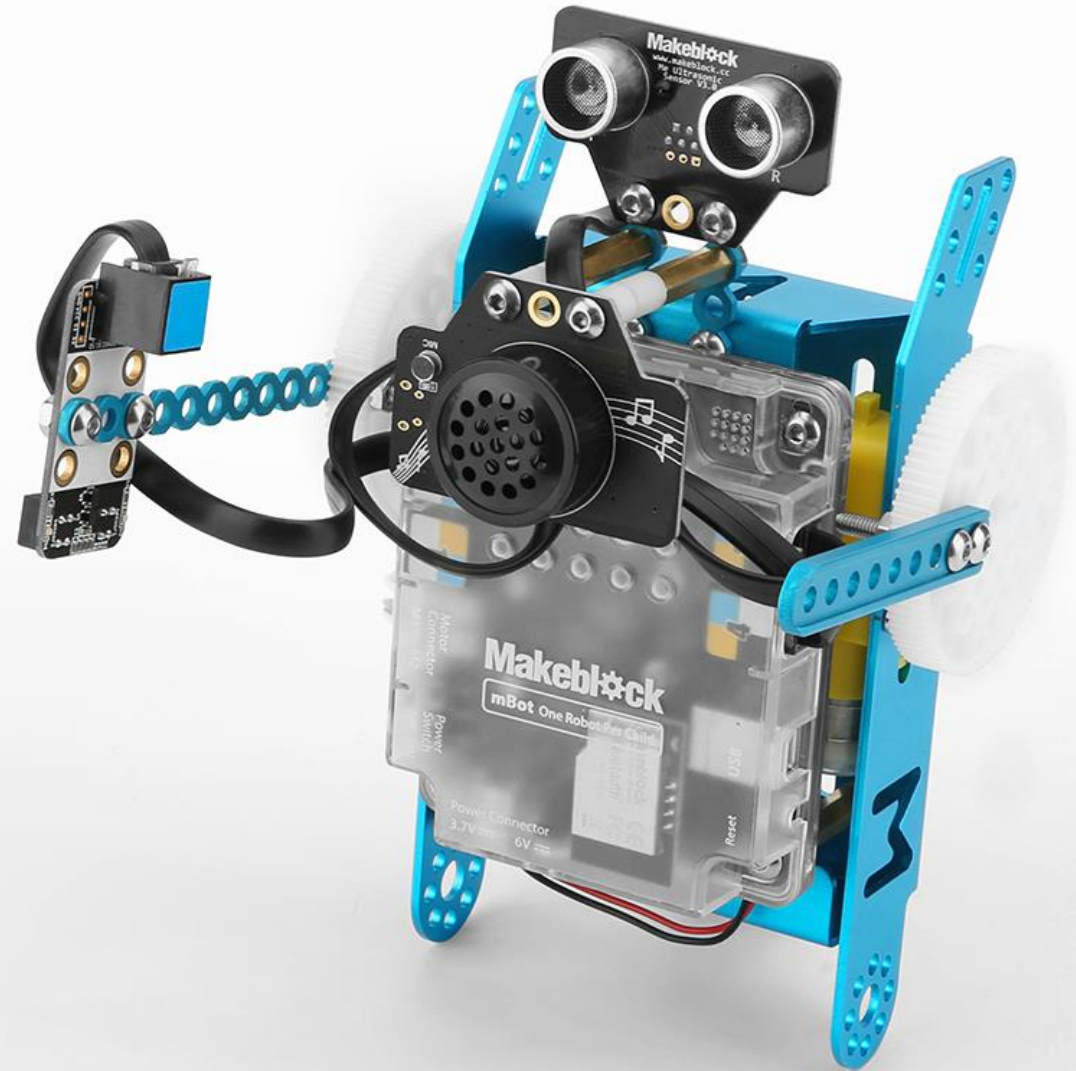

3-in-1 Model: Robot Penguin

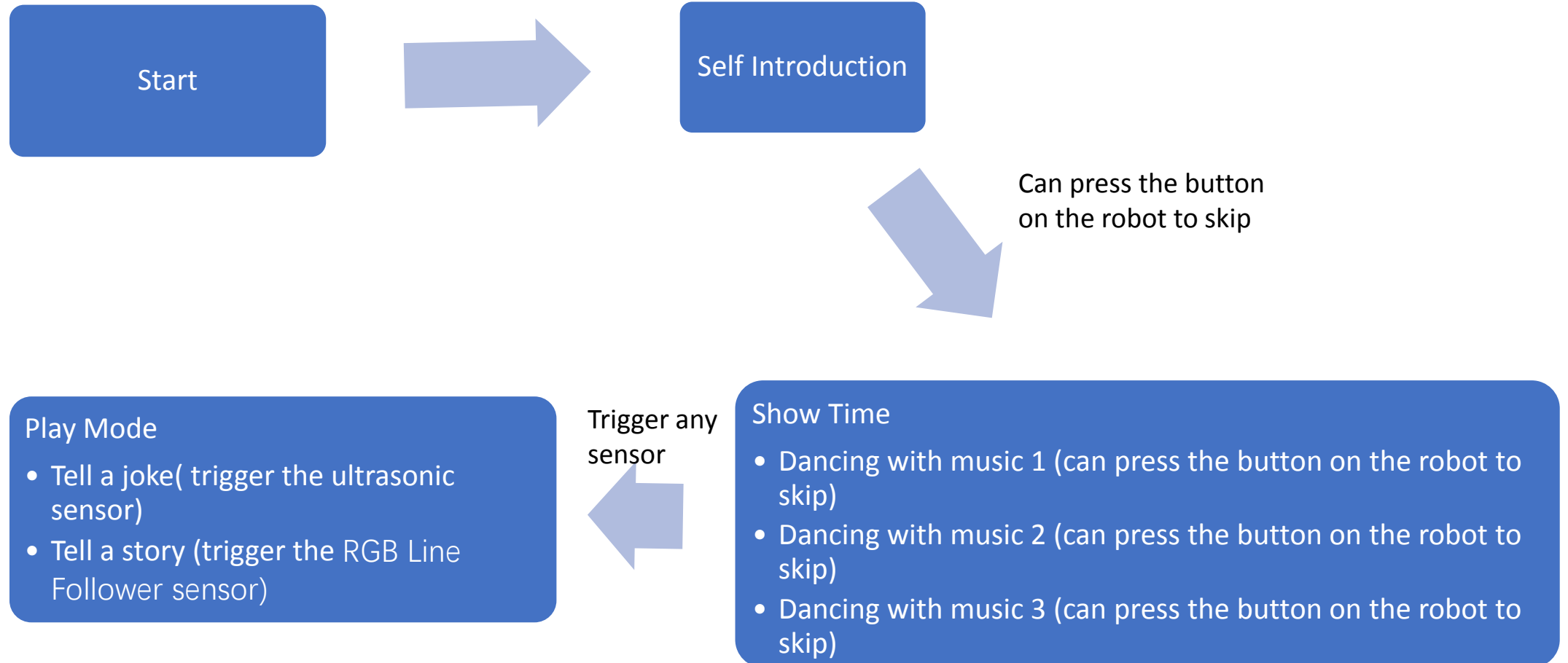

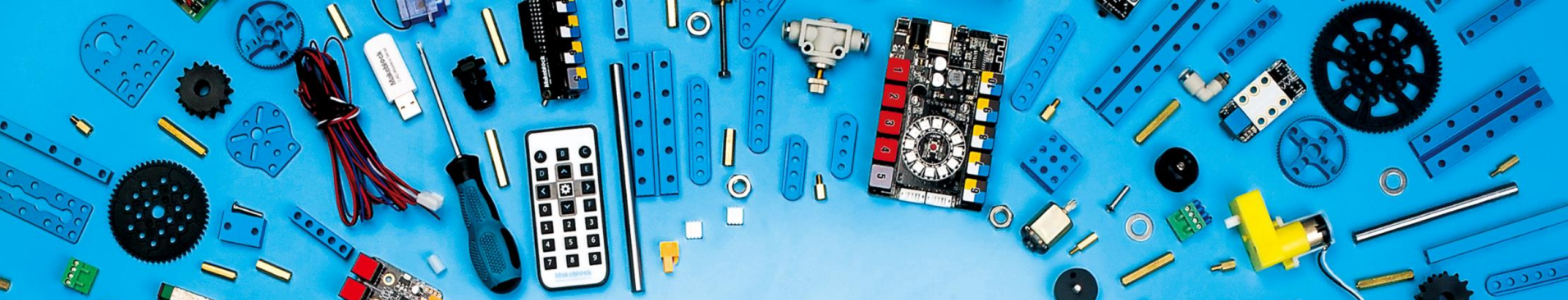

Thank You

Makeblock Co., Ltd. | www.makeblock.com | info@makeblock.com

